

DO NOT PRINT with INSTRUCTIONS

Information below is for LITHONIA documentation purposes only.
DO NOT include this page in the printing of this instruction sheet.

PART NUMBER: EMCSA00911

DESCRIPTION: INSTRUCTION SHEET, EU2C

SPECIFICATIONS: Prints 8.5 x 11, portrait. Two side, one color: BLACK ink.

PAGINATION: 8.5" X 11 portrait.

REQUIRED INSTRUCTION SHEETS for EU2C models				CONFIGURATIONS		
PART #	INSTRUCT SHEET DESCRIPTION	REV	DATE	STANDARD UNIT	HO	SDT
EMCSA00911	EU2C	B	09.12.2018	X	X	X
EMCSA00795	ABL LED WARNING			X	X	X
EMCSA00912	SD INSTRUCTIONS	A	08.06.2018			

DATE	CHANGE DESCRIPTION	BY
9.12.18	REV. B: Removed SD HO wiring diagram - ABL not offering SD and hO together at this time.	RRB
8.06.18	REV. A: Initial Release	RRM



An **Acuity** Brands Company

Lithonia Emergency

One Lithonia Way, Conyers GA 30012

Phone: 800-334-8694

www.lithonia.com

DO NOT PRINT with INSTRUCTIONS

INSTALLATION INSTRUCTIONS for Lithonia Lighting EU2C Models

LED DUAL HEAD EMERGENCY LIGHTING FIXTURE

READ AND FOLLOW ALL SAFETY INSTRUCTIONS

WARNING: FAILURE TO FOLLOW THESE INSTRUCTIONS AND WARNINGS MAY RESULT IN DEATH, SERIOUS INJURY OR SIGNIFICANT PROPERTY DAMAGE. For your protection, read and follow these warnings and instructions carefully before installing or maintaining this equipment. These instructions do not attempt to cover all installation and maintenance situations. If you do not understand these instructions or additional information is required, contact LITHONIA LIGHTING or your local LITHONIA LIGHTING distributor.

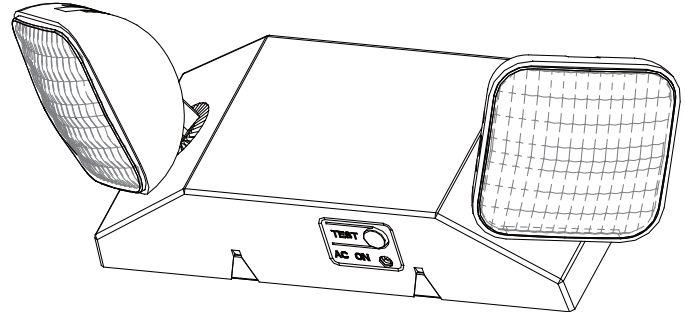

WARNING: RISK OF ELECTRIC SHOCK - NEVER CONNECT TO, DISCONNECT FROM, OR SERVICE WHILE EQUIPMENT IS ENERGIZED.

WARNING: RISK OF FIRE. Lamps are hot. Keep combustible material away from hot parts. Observe lamp manufacturer's warnings, recommendations and restrictions on lamp operation and maintenance. Make sure lamps are correctly installed.

CAUTION: The battery in this unit may not be fully charged. After electricity is connected to unit, let battery charge for at least 24 hours, then normal operation of this unit should take effect. To check, press the TEST button. The lamps on the unit should turn on.

NOTE: Complies with California Title 20. Product label is marked with **BC**.

IMPORTANT SAFEGUARDS: When using electrical equipment, basic safety precautions should always be followed, including the following:

- Do not use outdoors.
- Consult local building code for approved wiring and installation.
- Disconnect AC power before servicing and installation.
- Do not mount near gas or electric heaters.
- Do not use this equipment for anything other than its intended use.
- The use of accessory equipment not recommended by the manufacturer will void product listing and warranty and may cause an unsafe condition.
- Any service on this equipment should be performed by qualified personnel only.
- Equipment should be mounted in locations and at heights where it will not be subject to tampering by unauthorized personnel.
- Do not ceiling mount.
- Use caution when servicing batteries.
- Cap unused wires with enclosed wire nuts or other approved method.
- Make sure wire terminations are secure and leads are properly tucked in appropriate wire channels.

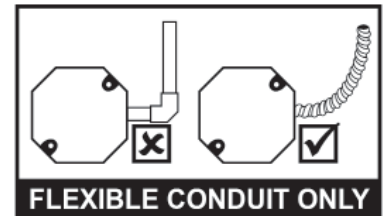

INSTALLATION:

NOTE: Max mounting height is 10 ft to achieve at least 1 ft-candle of illuminance in emergency mode.

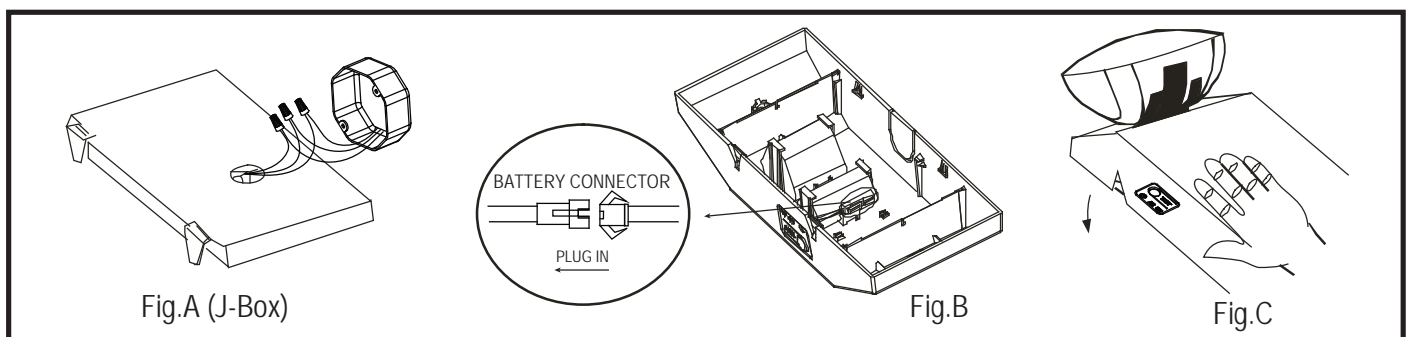

INSTALLATION INSTRUCTIONS

J-BOX MOUNTING:

1. Feed fixture leads through the back plate and connect to AC power supply (Fig A, page 1). For 120V use black and white wires and for 277V, use red and white wires.
2. Attach back plate to J-Box and secure with screws.
3. Complete the battery connection. (Fig. B, page 1)
4. Align snaps and push housing directly onto the back plate (Fig. C, page 1). Apply continuous AC power.
5. After the battery has been left to charge for 24 hours, test the unit by pushing the test switch and the LED lamp head will turn ON.

CONDUIT MOUNTING:

1. Secure back plate to wall surface using keyhole knockouts on the back plate.
2. Route wires through hole in conduit flange and make conduit connection. For 120V use black and white wires and for 277V, use red and white wires.
3. Complete the battery connection (Fig. B, page 1).
4. Align snaps and push housing directly onto the back plate. Apply continuous AC power.
5. After battery has been left to charge for 24 hours, test the unit by pushing the test switch and the LED lamp head will turn ON.

WALL MOUNTING:

1. Secure back plate to wall surface using keyhole knockouts on the back plate.
2. Feed fixture leads through back plate and connect to AC power supply. For 120V use black and white wires and for 277V, use red and white wires.
3. Complete the battery connection (Fig. B, page 1).
4. Align snaps and push housing directly onto the back plate. Apply continuous AC power.
5. After battery has been left to charge for 24 hours, test the unit by pushing the test switch and the LED lamp head will turn ON.

OPERATION:

1. During an electrical power failure, the LED lamps will automatically come on for a minimum of 90 minutes.
2. To test, press the "TEST" switch. The emergency LED lamps will illuminate and LED indicator will turn OFF. When the switch is released, the lamps will turn OFF and the LED indicator will turn ON.

LED STATUS INDICATOR KEY and TROUBLESHOOTING:

Visual Status	Indication	Troubleshooting/Actions to Take
RED	<ol style="list-style-type: none">1. Battery connection is not made.2. Battery has been diagnosed as dead or defective after 24 hours of continuous charging with AC power supplied.	<ol style="list-style-type: none">1. Make connection; or if battery is connected, disconnect battery for eight seconds and then reconnect.2. Replace the battery.
GREEN	Battery is connected, AC power has been supplied and fixture is in charging state.	This is the normal state. No action required.
UNLIT	AC power has not been supplied.	Supply AC power.

TESTING:

National Electric Code (NEC) and NFPA 101 regulations require that routine tests need to be performed as listed below: Once every month, the unit needs to be tested for duration of 30 seconds. Push in and hold the test switch to perform this test. Once every 12 months, a full 90 minute (per UL requirements) test needs to be performed on the unit. Disconnect power to the unit and leave it in the emergency mode. The lamps should stay ON for at least 90 minutes. Written records of the testing are to be kept for examination by the authority having jurisdiction.

TROUBLESHOOTING:

Condition - The emergency lights do not operate

1. If the charge indicator light is OFF: Check that the circuit breaker for AC supply is ON.
2. If the charge indicator light is ON: Check that battery is properly connected. If problem persists, Replace battery. If remote lamps (where applicable) are connected to the equipment, then turn OFF the AC supply and disconnect the remote circuit wires from the equipment. Turn ON the AC supply and depress the test switch. If the local lamps (mounted on the equipment itself) come ON, then check the remote circuit for short or overload condition and correct as required. Reconnect the circuit wires and restore AC power. If the local lamps don't turn ON after disconnecting the remote circuit wires, then replace battery.

Condition - Emergency lights are dim

1. Battery not fully charged. Allow battery to recharge for 24 hours and then retest. If lights are still dim, replace battery.

READ AND FOLLOW ALL SAFETY INSTRUCTIONS

WIRING DIAGRAMS

HO OPTION (REMOTE CAPABLE)

STANDARD

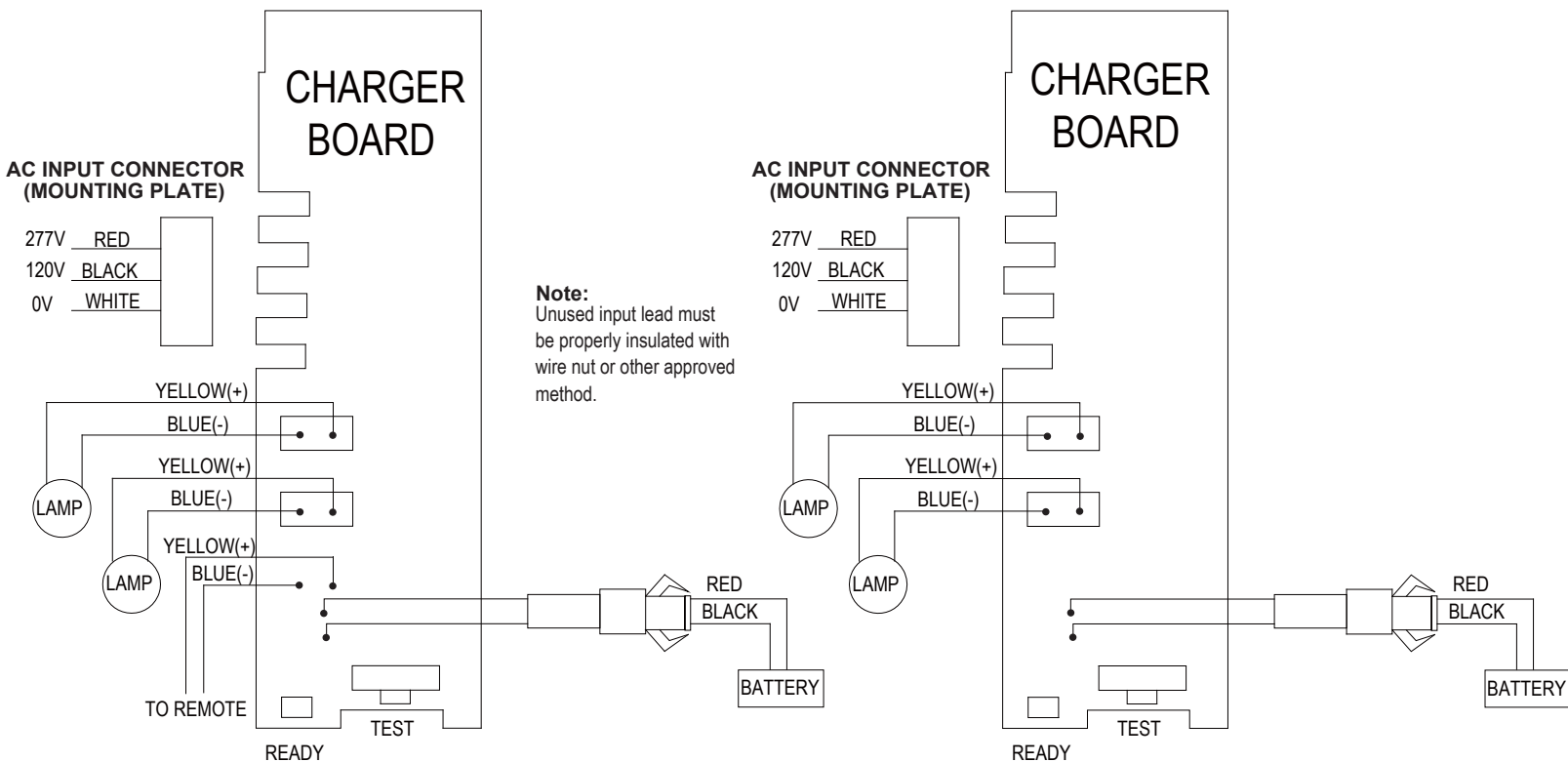

Note for HO models:
Use 18-22 AWG stranded wire to connect remote lamp heads.

INSTALLATION INSTRUCTIONS

SD OPTION

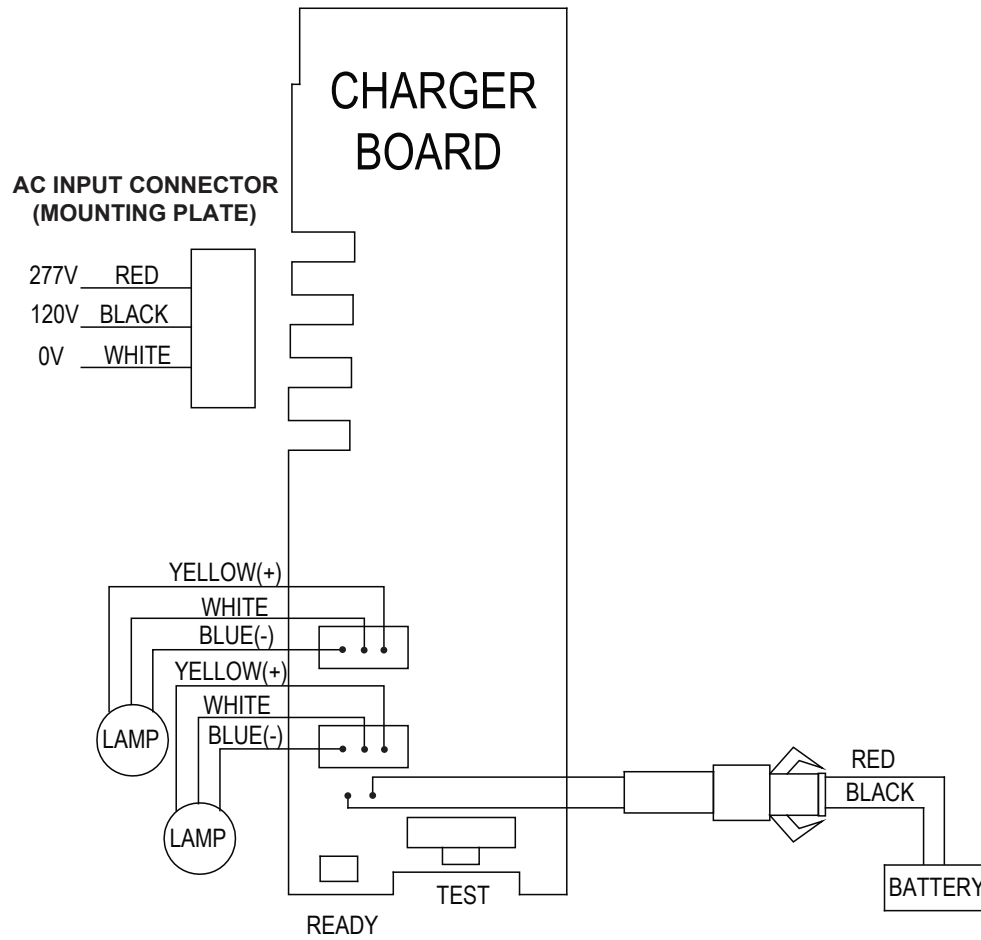

An AcuityBrands Company

Lithonia Emergency

One Lithonia Way, Conyers GA 30012

Phone: 800-334-8694

www.lithonia.com

Part No. EMCSA00911, REV B
2018.09.12