

IMPORTANT SAFEGUARDS

When using electrical equipment, basic safety precautions should always be followed including the following:

READ AND FOLLOW ALL SAFETY INSTRUCTIONS

1. To reduce the risk of electrical shock, turn off power supply before installation or servicing.
2. This luminaire must be installed in accordance with the NEC or your local electrical code. If you are not familiar with these codes and requirements, consult a qualified electrician.
3. DO NOT lift luminaire by the power leads.
4. Pendant kit is NOT supplied with luminaire.

SAVE THESE INSTRUCTIONS FOR FUTURE REFERENCE

INSTALLATION INSTRUCTIONS

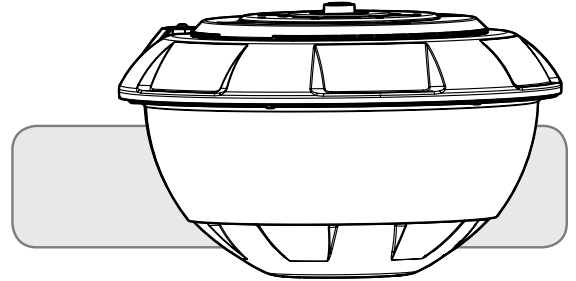

TO INSTALL:

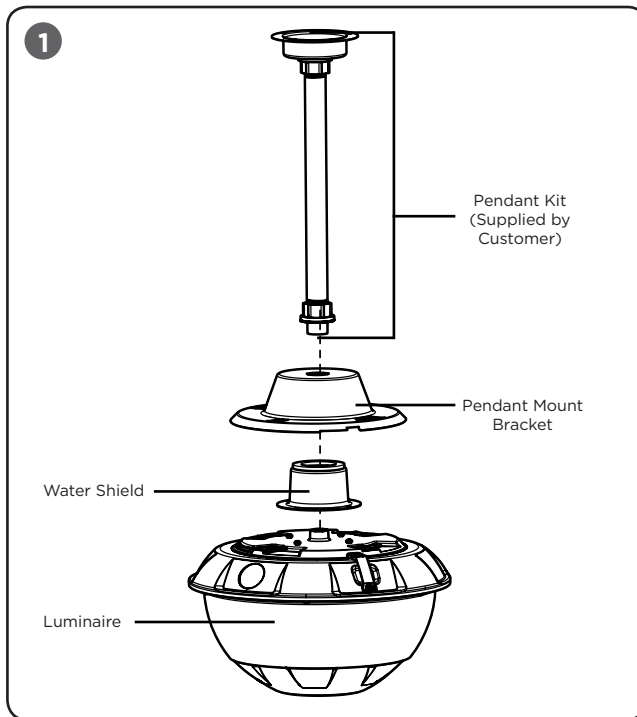

LUMINAIRE INSTALLATION

STEP 1:

Feed luminaire leads through the Water Shield and attach the Water Shield to the luminaire using (4) supplied #8 screws. See **Figure 1 and 2.**

STEP 2:

Attach Pendant Mount Bracket to customer supplied pendant kit. See **Figure 1.**

STEP 3:

Feed luminaire leads thru Pendant Mount Bracket and customer supplied pendant kit. See **Figure 1.**

STEP 4:

Position the arrow on the Pendant Mount Bracket to point towards the recessed area nearest to the latch on the luminaire. See **Figure 3.**

STEP 5:

Attach Pendant Mount Bracket and customer supplied pendant kit to luminaire by engaging the clips on the luminaire with the slots on the Pendant Mount Bracket and rotate until latch locks securely. See **Figure 3.**

NOTE: May require extra pressure on Pendant Mount Bracket to engage luminaire clips into slots.

NOTE: If the Pendant Mount Bracket slots become deformed during installation, slightly reopen the slots back up using a screwdriver to ensure proper install of luminaire.

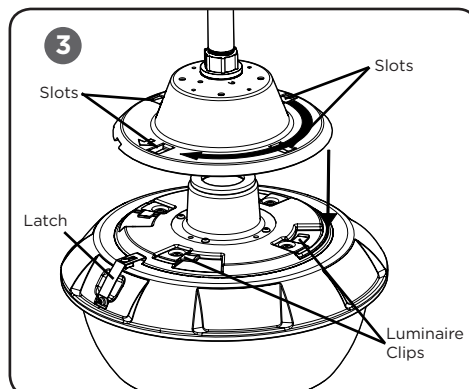
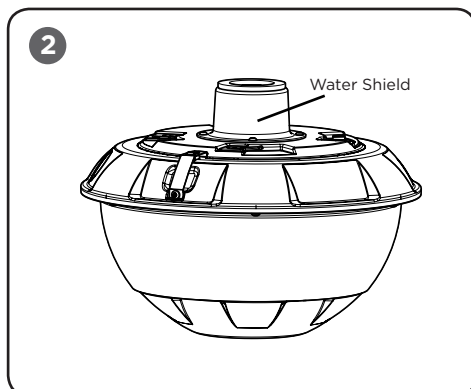

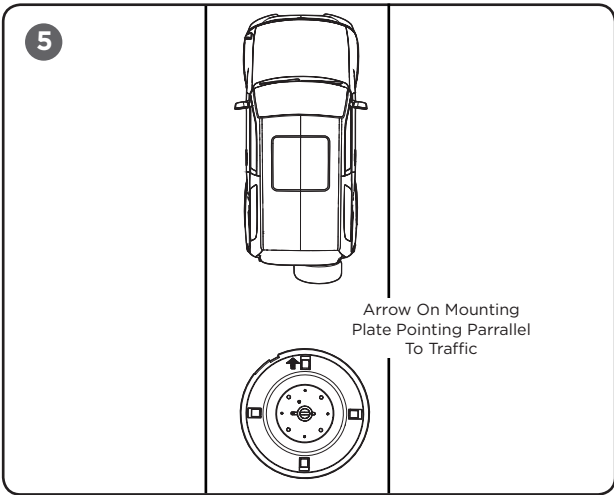
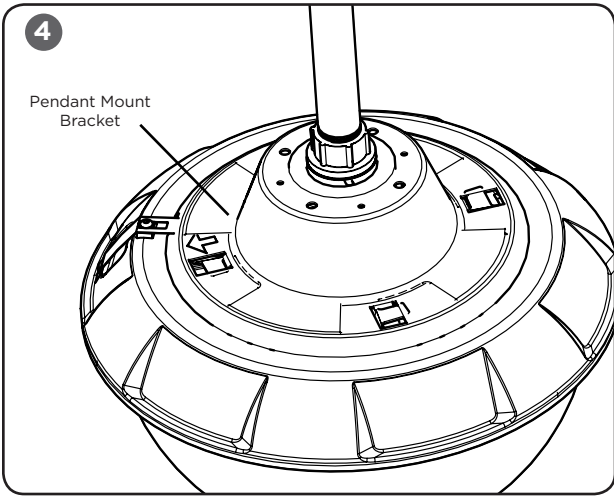

STEP 6:

Cut off any excess length of leads from the top of the customer supplied pendant kit.

STEP 7:

Make wiring connections to customer supplied junction box per **“Electrical Connections”** section.

STEP 8:

Using customer supplied hardware attach pendant kit and luminaire to customer supplied junction box with the arrow on the Pendant Mount Bracket directed parallel to vehicle traffic. See **Figure 5.**

ELECTRICAL CONNECTIONS

STEP 1:

Make the following Electrical Connections :

- a. For 120/277V connect the black fixture lead to the voltage supply position of the junction box (Hot 1 for 208/240V wiring).
- b. For 120/277V Connect the white fixture lead to the neutral supply position of the junction box (Hot 2 for 208/240V wiring).
- c. Connect the green or green/yellow ground lead to the green wire position of the junction box.
- d. If Dimming is an option; connect the violet dimming positive lead to the supply dimming positive lead.
- e. If Dimming is an option; connect the grey dimming negative lead to the supply dimming negative lead.

