



SENSORWORX®

LOW VOLTAGE CEILING MOUNT SENSORS

INSTALLATION & OPERATION INSTRUCTIONS

| CATALOG NUMBERS | DESCRIPTIONS |
|-----------------|--|
| SWX-201-1 | SMALL MOTION 360° CEILING SENSOR PASSIVE INFRARED (PIR) |
| SWX-202-1 | LARGE MOTION 360° CEILING SENSOR PASSIVE INFRARED (PIR) |
| SWX-221-1 | SMALL MOTION 360° CEILING SENSOR DUAL TECH (PIR/ACOUSTIC) |
| SWX-222-1 | LARGE MOTION 360° CEILING SENSOR DUAL TECH (PIR/ACOUSTIC) |

OVERVIEW

SENSORWORX sensors detect movement in the infrared energy that radiates from occupants as they move within the devices field-of-view. Once occupancy is identified, the sensor signals a power/relay pack to switch on the connected lighting. If equipped with passive dual technology (PIR/Acoustic), the unit's microphone is then enabled to further enhance detection while the lights are on. This overlapping passive acoustic occupancy detection is important for rooms with obstructions or where occupant motion will be limited. An internal timer is set to keep lights on during brief periods of inactivity, and is reset every time occupancy is signaled by either the passive infrared or acoustic detection technologies.

FEATURES

- **Digital Passive Infrared (PIR) Detection**
- **Passive Acoustic Detection (Optional)**
- **360° Coverage Pattern**
- **Compact Size and Matte Finish**
- **Four Contractor Friendly Mounting Methods**
- **Mounting Nipple Attachment with Integrated Hole Saw**
- **Convenient Test Mode and Adjustable Time Delays**

SPECIFICATIONS

ELECTRICAL

OPERATING VOLTAGE

12-24 VAC/VDC

CURRENT DRAW

2mA (PIR models)
10mA (Dual Tech. models)

OUTPUT

Logic High VDC (Occupied Mode)

RECOMMENDED POWER PACK

SWX-900 (**SENSORWORX**)

PHYSICAL

SIZE

4.00" Diameter x 1.25" H
(10.16 x 3.17 cm)

WEIGHT

4.75 oz

COLOR

White

ENVIRONMENTAL

OPERATING TEMP

-10°F to 122°F (14°C to 50°C)

RELATIVE HUMIDITY

0-95% Non-Condensing,
Indoor Use Only

OPERATION

TIME DELAYS

30 sec to 30 min
10 Minute Default

TEST MODE

5 sec

CODE COMPLIANCE

Sensors can be used to meet
ASHRAE 90.1, IECC, & Title 24
energy code requirements



SENSOR PLACEMENT

Typically, a sensor should be located such that all entrances to the room/space are adequately covered. Ideally, a sensor should be located so that its coverage beams are perpendicular to the door. This ensure that an occupant is detected immediately upon entering. See Diagram 1. Note, however, it is important to locate a sensor such that its coverage pattern can not extend through an open door, which could result in detection of persons walking by, but not into, a room.

If line of sight between a sensor and occupants is blocked (for example by a cubicle wall or stall), dual technology sensors should be alternatively utilized or additional PIR sensors should be added until line of sight is restored. Dual technology is recommended for all spaces where occupants are sitting or where motion within the space is limited (private offices, open offices, restrooms with stalls, libraries). Dual technology is not recommended for hallways or warehouses.

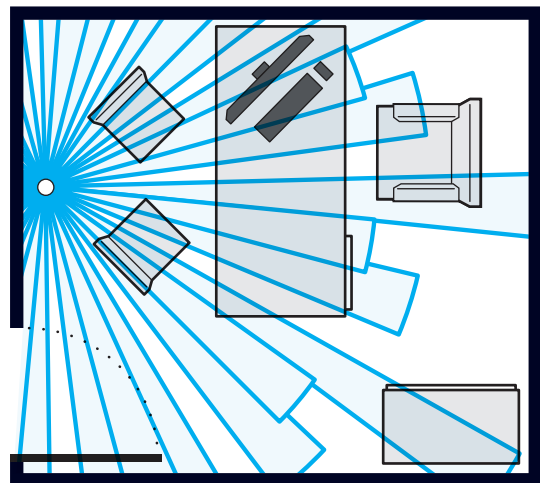

Diagram 1 - Recommended Sensor Placement in a Private Office

COVERAGE

PASSIVE INFRARED (PIR)

- 8 to 15 ft (2.44 to 4.57 m) mounting height recommended
- Detection range improves when walking across beams as compared to into beams
- Lenses can be swapped in field if necessary, contact technical support for assistance

SMALL MOTION 360°

- Best choice for detection of small motions from sitting occupants (e.g., hand motion)
- ~500 ft² of coverage

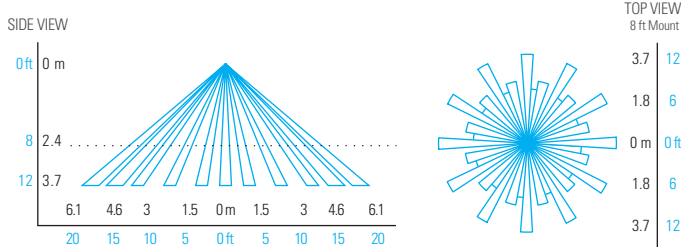

LARGE MOTION 360°

- Best choice for detection of larger motion (e.g., walking)
- ~2000 ft² of coverage
- Longest segment of coverage pattern aligns with screw hole axis on sensor (shown as dotted line on Top View diagram below)

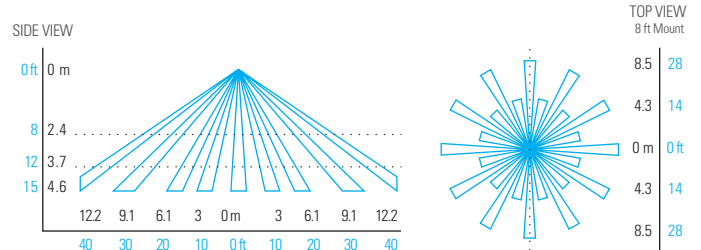

DUAL TECHNOLOGY (PIR/ACOUSTIC)

- Units with dual technology (SWX-221-1 and SWX-222-1) have overlapping acoustic detection of the complete PIR coverage area
- A PIR event is required to initially enable Acoustic detection
- Sounds indicating occupancy reset the sensor's time delay while non-occupant noises are filtered out
- Occupant sounds alone will not keep lights on indefinitely, PIR motion must be periodically detected for lights to remain on for an extended time
- After sensor time out expires, acoustic detection remains enabled for 10 seconds to enable voice reactivation of lights for additional convenience and safety

INSTALLATION INSTRUCTIONS

MOUNTING OPTIONS

- Chase nipple & lock nut (included) for mounting unit to ceiling tile or 1/2" knockout in junction box. See Side Diagram below.
- Screw holes for directly mounting to ceiling surface, 3-1/2" (trade size) octagon box, or mud ring with 2-3/4" spaced ears. See Front Diagram below.

INSTALLATION NOTES

- If mounting to ceiling tile, use the serrated end of the chase nipple to cut a 7/8" hole. Then thread the wires through nipple prior to screwing into rear of sensor. Install and tighten lock nut as needed.
- To install cover, line up dimples with indents on sensor and turn clockwise.

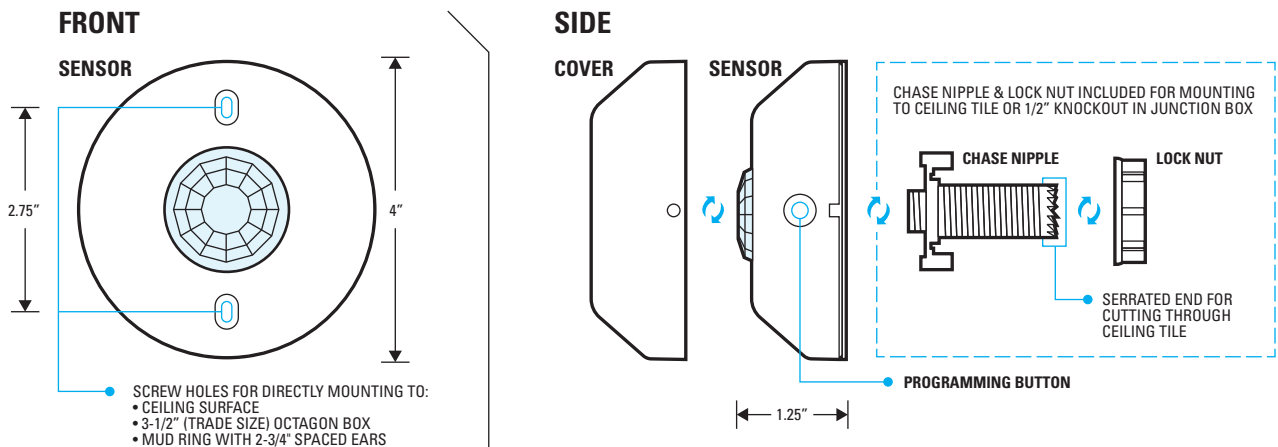

WIRING

STANDARD WIRING

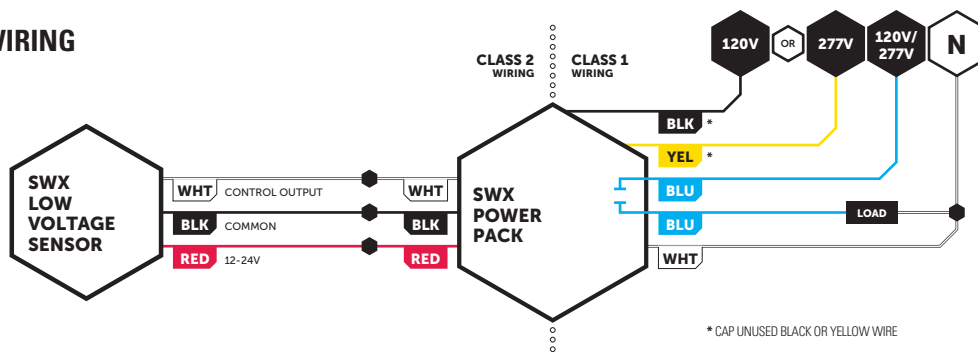

MULTIPLE SENSOR WIRING

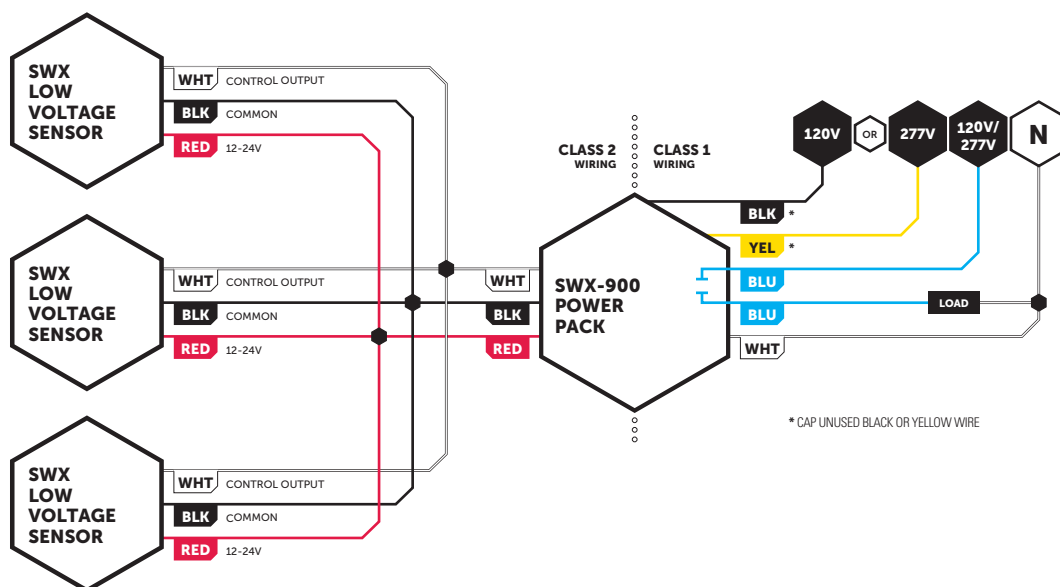

TESTING & TROUBLESHOOTING

TEST MODE

A test mode with a 5 second time delay is provided in order to efficiently perform walk testing. The sensor will blink White on any detected occupancy (PIR or Acoustic), although its time delay will only be reset by a PIR event.

TO PUT A SENSOR IN TEST MODE FOR 10 MINUTES:

- Press sensor's pushbutton 2 times, then wait two seconds.
- Press button 1 time to start test mode. After 10 minutes, the sensor's time delay will revert to previous setting.

RESET

To restore factory settings, press and release the pushbutton 8 times, wait 2 seconds, then press and release the pushbutton 3 times again.

CONFIGURATION SETTINGS

TIME DELAY CONFIGURATION

1. Read through the Time Delay Settings list and note the number of the desired time delay setting (e.g., default is 4 = 10 minutes).
2. Press and release the unit's pushbutton twice, then wait 2 seconds.
The White LED will blink back the number of the current setting.
3. At any time after blinking starts, enter number of new setting (from Time Delay Settings).
4. New setting is saved after White LED blinks new setting back 3 times.
If Blue LED double flashes at any time, start process over.

MICROPHONE

Dual technology sensors prevent non-occupant sounds from resetting the time delay by dynamically reducing the microphones sensitivity at specific frequencies. In some environments, decreasing the sensitivity across all frequencies so that lights go off sooner, may be preferred. A unit's microphone can also be disabled (effectively changing sensor to a PIR only version).

TO CHANGE MICROPHONE SETTINGS:

- Press unit's pushbutton 6 times, then wait two seconds. The White LED will blink back the number of current setting.
- Change to new setting by pressing the button equal times to below numbered choices:

| SETTING # | DESCRIPTION |
|-----------|----------------------------|
| 2 | Normal Operation [Default] |
| 3 | Reduced Sensitivity |
| 4 | Disabled |

- New setting will be saved after White LED blinks back number three times. If Blue LED double flashes at any time, start process over.

TIME DELAY SETTINGS

| SETTING # | DESCRIPTION |
|-----------|------------------|
| 1 | Test Mode** |
| 2 | 30 sec |
| 3 | 5 min |
| 4 | 10 min [Default] |
| 5 | 15 min |
| 6 | 20 min |
| 7 | 30 min |

** 5 SEC TIME DELAY, EXPIRES AFTER 10 MIN

LED INDICATION

By default, the sensor blinks its White LED whenever it detects PIR motion. A unit with dual technology will also blink the LED white when it acoustically detects occupancy. The intensity of this LED can be increased or disabled. Additionally, the LED can be enabled to blink white for only PIR events and blue for an acoustic event.

TO CHANGE LED INDICATION SETTINGS:

- Press unit's pushbutton 7 times, then wait two seconds. The White LED will blink back the number of current setting.
- Change to new setting by pressing the button equal times to below numbered choices:

| SETTING # | DESCRIPTION |
|-----------|--|
| 2 | White LED for all occupancy, normal brightness [Default] |
| 3 | White LED for all occupancy, increased brightness |
| 4 | Disable LED |
| 5 | White LED for PIR, Blue for Acoustic, normal brightness |
| 6 | White LED for PIR, Blue for Acoustic, increased brightness |

- New setting will be saved after White LED blinks back number three times. If Blue LED double flashes at any time, start process over.

